

Standard Equipment/Optional Equipment

Standard Equipment

Sinergo®, the operator/truck interface:

Power assisted steering
 Long tiller with low mounting point
 Creep speed control
 Linde Safety-Lift
 End-of-stroke resistance
 Dedicated work station (with storage compartments)
 OptiLift® proportional lift system on the tiller head
 Mast protection (polycarbonate or steel mesh)
 Multifunction coloured display with weighing device as well as hourmeter, maintenance indication, battery discharge indicator and internal fault code indication
 Weighing device information from the ground up to 1500 mm with +/- 50 kg accuracy
 2,3 kW AC motor (maintenance free)
 CAN bus technology

Vertical battery change 2 PzS (3 PzS on the 2 t version)
 Positive steering (drive wheel) feedback
 Automatic speed reduction when cornering
 Electromagnetic emergency brake
 Key switch or LFMgo (PIN-code access)
 Cushion drive wheel
 Polyurethane single load wheels
 Single castor wheel (1.4 t and 1.6 t versions)
 Double castor wheels (2 t version)
 Width over fork carriage: 560 mm, 680 mm (1.4 t and 1.6 t versions) or 580 mm (2 t version)
 Fork carriage length/thickness:
 1150 mm/71 mm or 55 mm (preferred while using gitter box), 1150 mm/73 mm on 2 t version
 Protection -10°C

Optional Equipment

Initial lift
 Proportional speed control
 Ultra fast lifting (up to +40%)
 Double castor wheels (1.4 t and 1.6 t versions)
 Soft landing of forks (free of charge)
 Drive wheels: polyurethane, wet grip, cushion with tread, polyurethane with tread or non marking
 Load wheels: tandem polyurethane, tandem polyurethane gresable
 Load backrests
 Lateral battery change 3 PzS (1.4 t and 1.6 t versions)
 Standard, Duplex or Triplex masts (Mast up to 5316 mm)

Alternative fork carriage length/thickness:
 950 mm / 71 mm or 55 mm (preferred while using gitter box), 950 mm / 73 mm on the 2 t version
 Linde Connected Solutions:
 ac:access control, an:usage analysis and dt:crash detection
 Pack Clipboard
 Mobile or Fixed battery stand (for lateral battery change)
 Automatic battery watering system
 Built-in charger
 Cold store protection -35°C

Other options available on request



Pedestrian Pallet Stacker Capacity 1400, 1600 and 2000 kg L14, L16, L20

Series 1173

Safety

The Linde pedestrian pallet stacker is a perfect fit for any stacking application. A weighing device enables to estimate load's weight up to 1500 mm so as to combine the information with the capacity plate for advanced safety. Safety-lift can be used for lifting with the tiller vertical while safety is assured as both hands remain on the controls.

Performance

High operational efficiency is this truck's true strength with its 2,3 kW AC motor. The robust chassis structure gives this truck exceptional residual capacity and offers capacities from 1400 kg up to a strengthened 2000 kg version complying with heavy load handling performances

Comfort

The OptiLift system, easy access to the controls and fingertip operation of the truck allow precise and comfortable handling. The proportional speed control option automatically reduces traction speed in relation to the distance between truck and operator.

Linde Material Handling



Features

Tiller & Tiller head

- With the soft fold back system, the tiller returns smoothly to the vertical position preventing impacts against the motor's cover
- Long tiller with low mounting point provides a large safety clearance between operator and chassis
- Easy-to-reach control buttons permit fingertip operation for utmost efficiency
- Wrap-around hand protection
- Twin grip steering control, operable with either hand for easy handling

Linde Weighing Device

- Weight estimation of the load carried up to 1500 mm
- Information available at a glance on a wide multifunctional display
- System accuracy +/- 50 kg



Lifting System

- OptiLift® mast control provides precise, fully proportional lifting
- Soft landing of the forks protects the load when lowering
- Initial lift version provides improved clearance on ramps and dock levellers
- Wide range of mast options available to suit any application



Multifunctional Display

- Important information about truck and the load
- Easy and ergonomic navigation within the different settings and information tabs
- Provides hourmeter, battery status and maintenance information



Brakes

- Automatic braking on release of traction butterfly or selecting the opposite direction
- Truck slows before coming to a stop, remaining under total control at all times
- Highly efficient electromagnetic brake applied by moving the tiller to fully up or down position
- Easy-to-reach emergency isolator on the top of the front cover

Steering System

- Electric power steering as standard ensures effortless driving
- Proportional speed control varies truck speed automatically in relation to tiller angle for safe operation
- Creep speed function allows for slow and highly maneuverable operation in confined areas with upright tiller
- End-of-stroke resistance on the tiller avoids accidental, abrupt braking

AC Motor

- Powerful, high torque 2,3 kW AC drive motor
- Moisture and dust-proof AC motor
- No rollback when starting on a slope
- Traction speed adjustable up to 6km/h, laden or unladen



Battery change

- Vertical battery change as standard
- Lateral change option includes:
- Rollers inside the battery compartment to aid battery change
- Lever initiates battery change preventing direct contact



Technical Data according to VDI 2198

		L14	L16	L20		
Characteristics	1.1	Manufacturer				
	1.2	Model designation				
	1.2a	Series				
	1.3	Power unit				
	1.4	Operation				
	1.5	Load capacity/Load	Q (t)	1.4	1.6	2.0
	1.6	Load centre	c (mm)	600	600	600
	1.8	Axle centre to fork face	x (mm)	724 (646) ^{1) 2)}	724 (646) ^{1) 2)}	724 (646) ^{1) 2)}
	1.9	Wheelbase	y (mm)	1311 (1233) ^{3) 1) 4) 2)}	1311 (1233) ^{3) 1) 4) 2)}	1425 (1347) ^{3) 1) 4) 2)}
Weights	2.1	Service weight	(kg)	1085 ^{4) 5)}	1085 ^{4) 5)}	1670 ^{4) 5)}
	2.2	Axle load with load, front/rear	(kg)	847 / 1638 ^{4) 5)}	866 / 1819 ^{4) 5)}	1296 / 2374 ^{4) 5)}
	2.3	Axle load without load, front/rear	(kg)	715 / 370 ^{4) 5)}	715 / 370 ^{4) 5)}	1122 / 548 ^{4) 5)}
Wheels/Tyres	3.1	Tyres rubber, SE, pneumatic, polyurethane				
	3.2	Tyre size, front	Ø 230 x 90	Ø 230 x 90	Ø 230 x 90	
	3.3	Tyre size, rear	Ø 85 x 85 (Ø 85 x 60) ⁷⁾	Ø 85 x 85 (Ø 85 x 60) ⁷⁾	Ø 85 x 105 (Ø 85 x 60) ⁷⁾	
	3.4	Auxiliary wheels (dimensions)				
	3.5	Wheels, number front/rear (x = driven)				
	3.6	Track width, front	b10 (mm)	534 ²⁾	534 ²⁾	534 ²⁾
	3.7	Track width, rear	b11 (mm)	380 ²⁾	370 ²⁾	370 ²⁾
Dimensions	4.2	Height of mast, lowered	h1 (mm)	1915 ²⁾	1915 ²⁾	1915 ²⁾
	4.3	Free lift	h2 (mm)	150 ²⁾	150 ²⁾	150 ²⁾
	4.4	Lift	h3 (mm)	2844 ²⁾	2844 ²⁾	2684 ²⁾
	4.5	Height of mast, extended	h4 (mm)	3364 ²⁾	3364 ²⁾	3284 ²⁾
	4.9	Height of tiller arm in operating position, min/max	h14 (mm)	697.5 / 1162.5	697.5 / 1162.5	697.5 / 1162.5
	4.15	Height, lowered	h13 (mm)	86	86	86
	4.19	Overall length	l1 (mm)	1950 ^{3) 2)}	1950 ^{3) 2)}	2068 ^{3) 2)}
	4.20	Length to fork face	l2 (mm)	800 ^{3) 2)}	800 ^{3) 2)}	915 ^{3) 2)}
	4.21	Overall width	b1/b2 (mm)	800 ²⁾	800 ²⁾	810 ²⁾
	4.22	Fork dimensions	s/e/l (mm)	71 x 180 x 1150	71 x 180 x 1150	73 x 210 x 1150
	4.24	Width of fork carriage	b3 (mm)	780 ²⁾	780 ²⁾	780 ²⁾
	4.25	Fork spread, min/max	b5 (mm)	560 / 680 ²⁾	560 / 680 ²⁾	580 / 680 ²⁾
	4.26	Width between reach legs	b4 (mm)	255 / 375	255 / 375	230 / 330
	4.32	Ground clearance, centre of wheelbase	m2 (mm)	30 (20/140) ^{8) 1) 9)}	30 (20/140) ^{8) 1) 9)}	14 (20/115) ^{8) 1) 9)}
	4.33	Aisle width with pallet 1000 x 1200 across forks	Ast (mm)	2463 (2576) [2385 (2422)] ^{10) 11) 12) 13) 14)}	2463 (2576) [2385 (2422)] ^{10) 11) 12) 13) 14)}	2578 (2691) [2500 (2537)] ^{10) 11) 12) 13) 14)}
4.34	Aisle width with pallet 800 x 1200 along forks	Ast (mm)	2349 (2462) [2271 (2384)] ^{10) 11) 12) 13) 14)}	2349 (2462) [2271 (2384)] ^{10) 11) 12) 13) 14)}	2464 (2577) [2386 (2499)] ^{10) 11) 12) 13) 14)}	
4.35	Turning radius	Wa (mm)	1527 ^{15) 3)}	1527 ^{15) 3)}	1642 ^{16) 3)}	
Performance	5.1	Travel speed, with/without load	(km/h)	6 / 6 ¹⁷⁾	6 / 6 ¹⁷⁾	6 / 6 ¹⁷⁾
	5.2	Lifting speed, with/without load	(m/s)	0.16 / 0.3 (0.4) ^{18) 5)}	0.15 / 0.3 (0.4) ^{18) 5)}	0.12 / 0.25 (0.35) ^{18) 5)}
	5.3	Lowering speed, with/without load	(m/s)	0.4 / 0.35 ⁹⁾	0.4 / 0.35 ⁹⁾	0.35 / 0.25 ⁹⁾
	5.8	Maximum climbing ability, with/without load	(%)	10.0 / 24.0	10.0 / 24.0	8.0 / 24.0
5.10	Service brake		electric/mechanic	electric/mechanic	electric/mechanic	
Drive	6.1	Drive motor, 60 minute rating	(kW)	2.3	2.3	2.3
	6.2	Lift motor, rating at S3 15%	(kW)	3.2	3.2	3.2
	6.3	Battery according to DIN 43531/35/36 A,B,C,no		43 535 / B / 2PzS	43 535 / B / 2PzS	43 535 / B / 3PzS
	6.4	Battery voltage/rated capacity (5h)	(V/Ah)	24 / 250	24 / 250	24 / 270
	6.5	Battery weight (± 5%)	(kg)	212	212	249
	6.6	Power consumption according to VDI cycle	(kWh/h)	1.47	1.47	1.52
Others	8.1	Type of drive control		LAC w. microprocessor	LAC w. microprocessor	LAC w. microprocessor
	8.4	Noise level at operator's ear	(dB(A))	< 66	< 66	< 66

1) Figures in parenthesis with initial lift
 2) (± 5 mm)
 3) ± 0 mm = 2 PzS vertical; + 75 mm = 3 PzS vertical; + 150 mm = 4 PzS vertical
 4) Figures with battery, see line 6.4/6.5.
 5) (± 10%)
 6) Solid rubber + polyurethane / polyurethane
 7) Figures in parenthesis with tandem load wheels.
 8) Without/with initial lift
 9) (± 2 mm)
 10) Values in parenthesis with bumper
 11) With creep speed = tiller in vertical position

12) [with initial lift]
 13) Including a 200 mm (min.) operating aisle clearance.
 14) (± 20 mm)
 15) with initial lift Wa = 1449 mm, with bumper Wa = 1640 mm, with initial lift and bumper Wa = 1562 mm
 16) with initial lift Wa = 1564 mm, with bumper Wa = 1755 mm, with initial lift and bumper Wa = 1677 mm
 17) (± 5%)
 18) figures in parenthesis for optional „Lift Speed Booster“

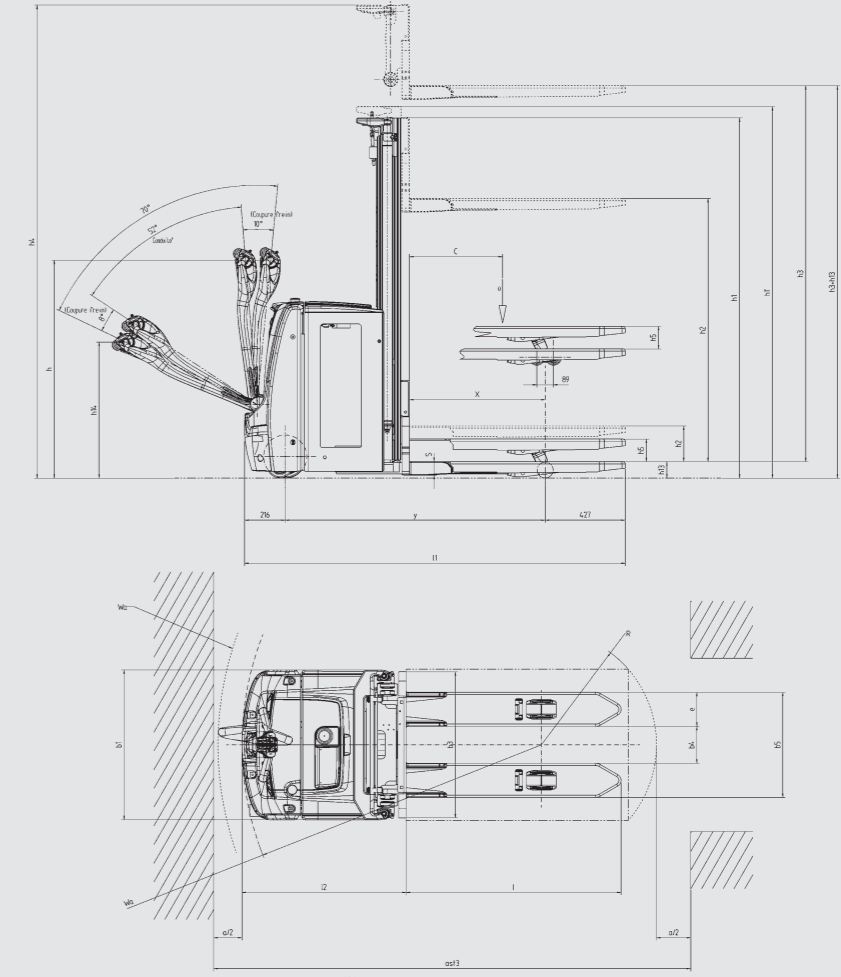

Mast 1.4 and 1.6 t (in mm)		1844 S	2344 S	2844 S	3244 S	3744 S	4144 S	4644 S	1844 D	2344 D
Lift	h3	1844	2344	2844	3244	3744	4144	4644	1844	2344
Lift + fork height	h3+h13	1930	2430	2930	3330	3830	4230	4730	1930	2430
Height, mast lowered	h1	1415	1665	1915	2115	2365	2565	2815	1415	1665
Closed height (with free lift at 150 mm)	h1#	1490	1740	1990	2190	2440	2640	2890	-	-
Height, mast extended	h4	2364	2864	3364	3764	4264	4664	5164	2364	2864
Free lift	h2	150	150	150	150	150	150	150	895	1145

Mast 1.4 and 1.6 t (in mm)		2844 D	3244 D	3744 D	4144 D	3516 T	4266 T	4716 T	5316 T
Lift	h3	2844	3244	3744	4144	3516	4266	4716	5316
Lift + fork height	h3+h13	2930	3330	3830	4230	3602	4352	4802	5402
Height, mast lowered	h1	1915	2115	2365	2565	1665	1915	2065	2265
Closed height (with free lift at 150 mm)	h1#	1915	2115	2365	2565	1665	1915	2065	2265
Height, mast extended	h4	3364	3764	4264	4664	4036	4786	5236	5836
Free lift	h2	1395	1595	1845	2045	1145	1395	1545	1745

Mast 2 t (in mm)		2684 S	3084 S	3584 S	2684 D	3084 D	3584 D	3276 T	4026 T	4476 T
Lift	h3	2684	3084	3584	2684	3084	3584	3276	4026	4476
Lift + fork height	h3+h13	2770	3170	3670	2770	3170	3670	3362	4112	4562
Height, mast lowered	h1	1915	2115	2365	1915	2115	2365	1665	1915	2065
Closed height (with free lift at 150 mm)	h1#	1990	2190	2440	-	-	-	-	-	-
Height, mast extended	h4	3284	3684	4184	3284	3684	4184	3876	4626	5076
Free lift	h2	150	150	150	1315	1515	1765	1065	1315	1465

Other masts on request
 S=Standard, D=Duplex, T=Triplex